

1 Clamp the jig in the correct position. Drill through all bushes marked 1 with a $\varnothing 7,2$ mm drill bit. Then drill through all bushes marked 2 with a $\varnothing 3,0$ mm drill bit.

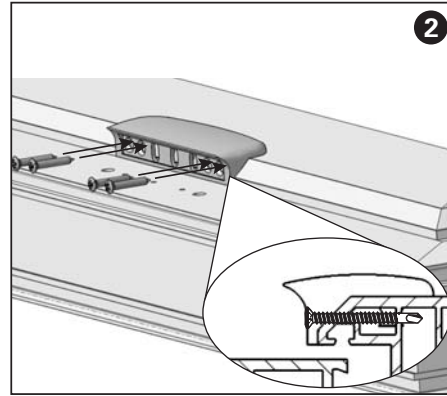

2 Fasten the sash plate with screws M 3,9 x 38 mm.

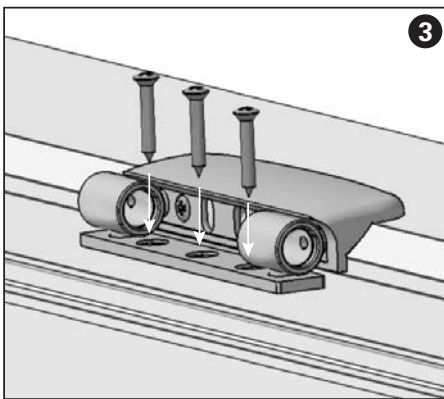

3 Fasten the frame plate with fastener 3,9 x 38 mm. **IMPORTANT:** ensure that the grub screw holes are positioned towards the door sash.

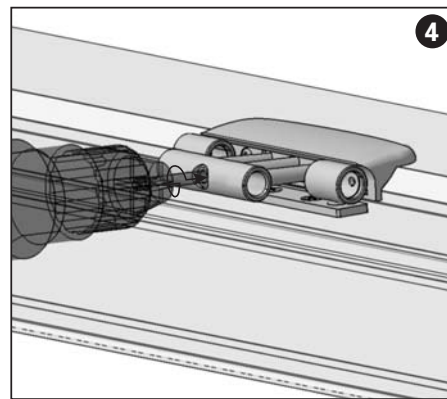

4 Drive in the central barrel section until it lines up with the rings in the frame plate.

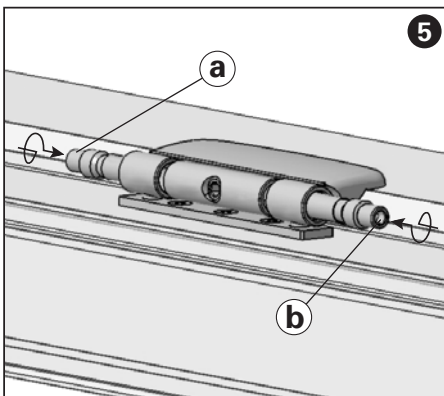

5 Drive in pin **a** flush fit to the upper ring. Drive in pin **b** till it touches the central barrel section.

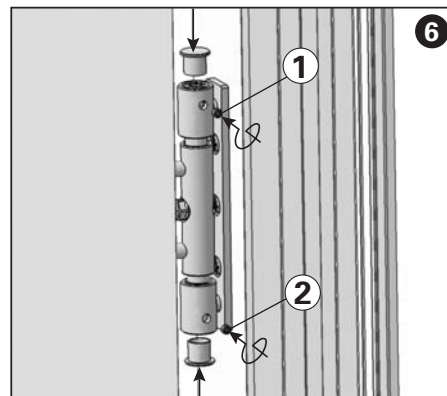

6 Fit the caps and fasten the security screws 1 and 2.

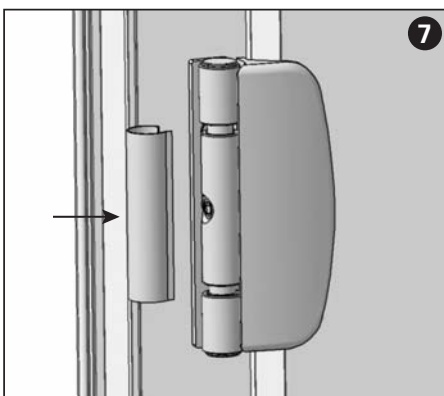

7 Fit the cover cap on the central barrel.

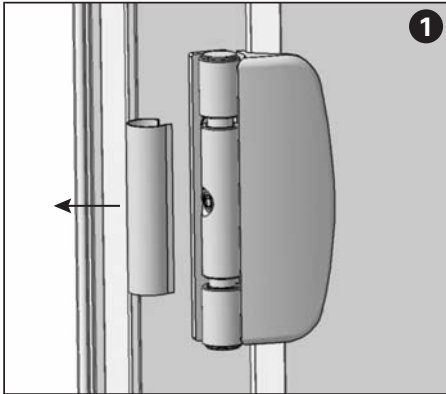

1 Remove the cover cap.

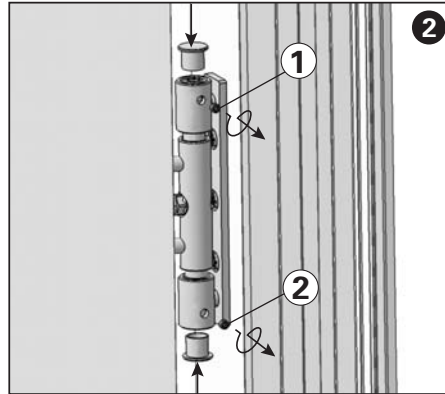

2 Unscrew the security screws and remove the caps.

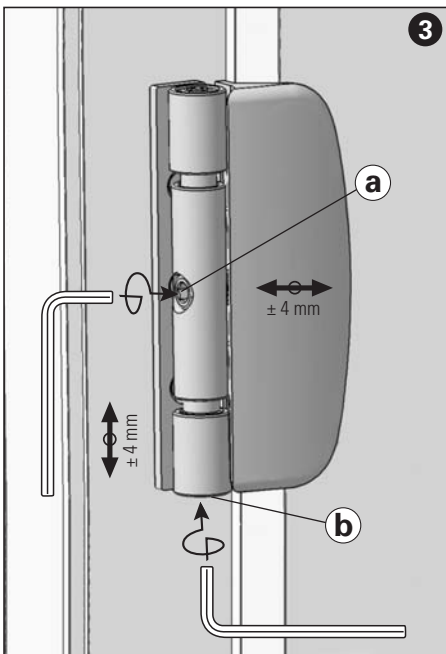

3 **Horizontal adjustment:** adjust by turning screw **a** with a 5 mm Allen Key.
Height adjustment: adjust by turning screw **b** with a 5 mm Allen Key.

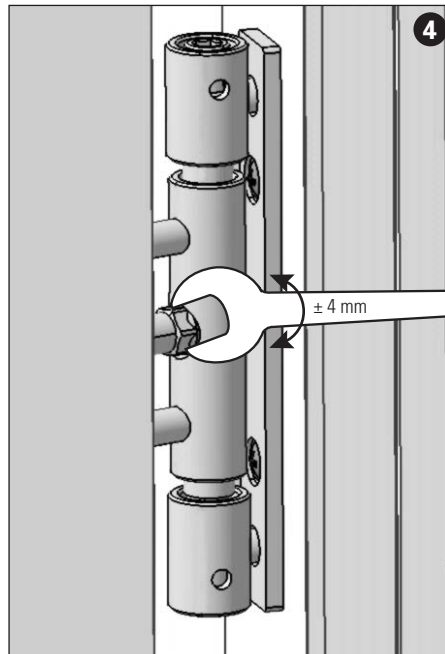

4 In difficult situations it is possible to make the horizontal adjustment from inside turning the hexagonal nut with a 9 mm spanner.

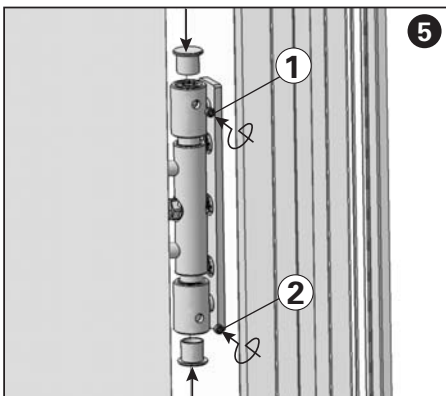

5 Refit the caps and fasten the security screws 1 and 2.

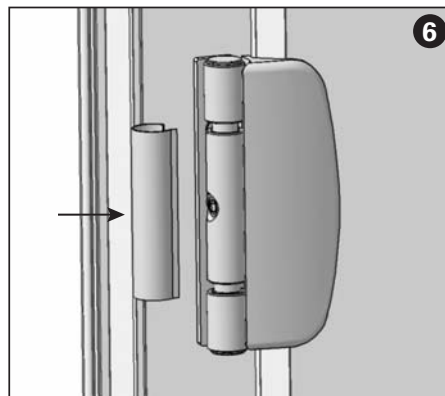

6 Refit the cover cap on the central barrel.